

ORIGINAL INSTRUCTIONS

**FEIDER**  
MACHINES

**GASOLINE LAWN MOWER**

FTDT4640ES



**WARNING: READ THE INSTRUCTIONS BEFORE USE THE TOOL**

**FEIDER**

**32, rue Aristide Bergès - ZI 31270 Cugnaux – France**

**Made in China 2020**

**CE**

# 1. DESCRIPTION OF SYMBOLS

Symbols are used in this manual to attract your attention to possible risks. The safety symbols and the explications which accompany them must be perfectly understood. The warning themselves do not prevent the risks and can not be a substitute for proper methods of avoiding accidents.



This symbol, before a safety comment, indicates a precaution, a warning or a danger. Ignoring this warning can lead to an accident for yourself or for others. To limit the risk of injury, fire or electrocution always applies the recommendations indicated.



Before any use, refer to the corresponding paragraph in the present manual.



Keep other people out of the dangerous area.



Remove the ignition cable before all maintenance work, and read the instructions for use.



Wear hearing protection and eye protection when using the device.



Warning - Moving blades. Keep hands and feet away when the machine is operated. Do not attempt to clear grass from the rear chute area while the blade is still rotating. The exhaust and other parts of the engine will get very hot during use, do not touch.



Fuel is flammable, keep fire away. Do not add fuel with running machine.



Caution- hot surface - Do not touch hot surfaces - Danger of burns!



Danger! Do not near the operational machine!



Guarantee sound power level

## 2. SAFETY INSTRUCTIONS

### *Training*

- a) Read the instructions carefully. Be familiar with the controls and the proper use of the equipment.
- b) Never allow children or people unfamiliar with these instructions to use the lawnmower. Local regulations can restrict the age of the operator.
- c) Never mow while people, especially children, or pets are nearby.
- d) Keep in mind that the operator or user is responsible for accidents or hazards occurring to other people or their property.

### *Preparation*

- a) While mowing, always wear substantial footwear and long trousers. Do not operate the equipment when barefoot or wearing open sandals.
- b) Thoroughly inspect the area where the equipment is to be used and remove all objects which can be thrown by the machine.
- c) **WARNING** — Petrol is highly flammable:
  - Store fuel in containers specifically designed for this purpose;
  - refuel outdoors only and do not smoke while refuelling;
  - add fuel before starting the engine. Never remove the cap of the fuel tank or add petrol while the engine is running or when the engine is hot;
  - If petrol is spilled, do not attempt to start the engine but move the machine away from the area of spillage and avoid creating any source of ignition until petrol vapors have dissipated;
  - replace all fuel tank and container caps securely.
- d) Replace faulty silencers.
- e) Before using, always visually inspect to see that the blades, blade bolts and cutter assembly are not worn or damaged. Replace worn or damaged blades and bolts in sets to preserve balance.
- f) On multi-bladed machines, take care as rotating one blade can cause other blades to rotate.
  - Replace defective mufflers.
  - Before use, always inspect visually that the blades, blade assembly and blade lock are not worn or damaged. Replace blades and blade assemblies that are not in good condition to maintain balance. Always use

recommended blades. Contact the manufacturer or your dealer in order to have a list of recommended blades. Non-recommended blades can give a risk of malfunctions, injuries and accidents.

- The blades must be balanced to ensure proper operation and to be able to work safely.

### ***Operation***

- a) Do not operate the engine in a confined space where dangerous carbon monoxide fumes can collect.
- b) Mow only in daylight or in good artificial light.
- c) Avoid operating the equipment in wet grass, where feasible.
- d) Always be sure of your footing on slopes.
- e) Walk, never run.
- f) For wheeled rotary machines, mow across the face of slopes, never up and down.
- g) Exercise extreme caution when changing direction on slopes.
- h) Do not mow excessively steep slopes.
- i) Use extreme caution when reversing or pulling the lawnmower towards you.
- j) Stop the blade(s) if the lawnmower has to be tilted for transportation when crossing surfaces other than grass, and when transporting the lawnmower to and from the area to be mowed.
- k) Never operate the lawnmower with defective guards, or without safety devices, for example deflectors and/or grass catchers, in place.
- l) Do not change the engine governor settings or over speed the engine.
- m) Disengage all blades and drive clutches before starting the engine.
- n) Start the engine or switch on the motor carefully according to instructions and with feet well away from the blade(s).
- o) Do not tilt the lawnmower when starting the engine or switching on the motor, except if the lawnmower has to be tilted for starting. In this case, do not tilt it more than absolutely necessary and lift only the part which is away from the operator.
- p) Do not start the engine when standing in front of the discharge chute.
- q) Do not put hands or feet near or under rotating parts. Keep clear of the discharge opening at all times.

- r) Never pick up or carry a lawnmower while the engine is running.
- s) Stop the engine and disconnect the spark plug wire, make sure that all moving parts have come to a complete stop and, where a key is fitted remove the key:
  - Before clearing blockages or unclogging chute;
  - Before checking, cleaning or working on the lawnmower;
  - After striking a foreign object. Inspect the lawnmower for damage and make repairs before restarting and operating the lawnmower;
  - If lawnmower starts to vibrate abnormally (check immediately).
- t) Stop the engine and disconnect the spark plug wire, make sure that all moving parts have come to a complete stop and, where a key is fitted remove the key:
  - Whenever you leave the lawnmower;
  - Before refuelling.
- u) Reduce the throttle setting during engine shut down and, if the engine is provided with a shut-off valve, turn the fuel off at the conclusion of mowing.
- v) Go slow when using a trailing seat.

### ***Maintenance and storage***

- a) Keep all nuts, bolts and screws tight to be sure the equipment is in safe working condition.
- b) Never store the equipment with petrol in the tank inside a building where fumes can reach an open flame or spark.
- c) Allow the engine to cool before storing in any enclosure.
- d) To reduce the fire hazard, keep the engine, silencer, battery compartment and petrol storage area free of grass, leaves, or excessive grease.
- e) Check the grass catcher frequently for wear or deterioration.
- f) Replace worn or damaged parts for safety.
- g) If the fuel tank has to be drained, this should be done outdoors.

### **Special safety instructions**

- Always use the mower with its pick-up bag and / or deflector in the intended position.

- Switch off the engine before emptying the pick-up bag or before changing the cutting height.
- While the engine is running, never put your hands or feet under the mower or under the grass ejection area.
- Before mowing, remove all foreign objects from the grass that can be propelled by the machine.
- Keep children and pets at a safe distance while using the mower.
- Never lift the mower when the engine starts.
- Alcohol, drug, as well as illness, fever and fatigue affect your ability to respond. Do not use power tools in such circumstances.
- Never change the rated speed of the motor.
- Never lift or carry the tool while the engine is running.
- Before starting the engine, release the drawbar.
- Before mowing, install the collection bag in its intended position.
- Do not use the mower in the event of rain or when the grass is wet.
- Never lift the rear of the mower when starting the engine and never place your hands or feet under the mower deck or in the rear ejection port while the engine is running.
- Turn off the engine and remove the spark plug cap in the following cases:
  - Before operating under the mower deck or near the ejection opening.
  - Before any maintenance, repair or verification.
  - Before transporting, lifting or storing the mower.
  - If you leave the mower unattended or change the cutting height.
  - To remove and empty the collection bag.
- After striking a foreign object, turn off the engine and carefully inspect the mower for damage. Take the lawnmower to an authorized service center for repair if necessary.
- If the mower vibrates abnormally, try to understand the reason and bring your lawnmower to an authorized repair center.
- Regularly check that the bolts, nuts and screws are properly tightened for safe use of the mower.
- Do not use the tool where there is a risk of lighting.
- Use the tool on daylight or under a good lighting. Always keep bystanders away.

- Warning: Take an extreme precaution when operating the lawnmower in slopes and near drop-offs, ditches or embankments; always be sure of your footing and stay in alert.
- the lawnmower safety systems or features shall not be tampered with or disabled;
- the operator should not alter or tamper with any sealed adjustments for the engine speed control;
- The operator must have, before using the tool for the first time, an adequate training with an experienced people.
- Warning: do not use of the unit while being tired, ill or under influence of alcohol or other drugs;
- Park safely the tool before leave it. The tool must be switched off.
- The lawnmower shall not be operated without either the entire grass catcher or self-closing discharge opening guard in place;
- Warning: be careful about exhaust gas. Do not inhale them.
- Wear adequate clothing such as long trousers and a protective equipment: slip-resistant foot protection, hearing protection, eyes protection and gloves.
- To avoid health issues, limit the time of operation. Take enough rest. Exposure to noise and vibrate can have bas consequences on health.
- WARNING: There is a danger about moving blade assemblies. Always handle blades when they are in a complete stop and wear protective gloves.

### **Fuel Handling**

Use caution when handling fuels. They are flammable and the vapours are explosive.

Use only an approved container.

Never remove the fuel cap or add fuel while the machine is on. Turn off the unit and allow the engine and exhaust components to cool down before refuelling.

Do not smoke.

Never refuel inside a room.

Never store the tool and the fuel tank indoors where there is a naked flame, such as near a water heater.



If fuel has spilled, do not attempt to start the machine, but move it away from the spill before starting to use it. Please clean up any spills.

Replace and tighten the fuel tank cap after refuelling.

Follow strictly the instructions in this manual for filling the tool with fuel.

### **During maintenance and storage**

Switch off the tool and wait until it stops completely. Make sure that all moving parts are stopped.

Allow the machine to cool before performing inspection, adjustments, maintenance, servicing and storage.

Store the tool where fuel vapour will not reach a flame or spark.

The transport of the tool must be secured in order to avoid fuel spillage, accidents and injuries.

### **Residual risks**

Even if you use this product in compliance with all safety requirements, the potential risks of injury and damage remain. The following hazards may arise in the structure and design of this product:

There are risks of injury and property damage due to attachments or broken the sudden impact of hidden objects when using cutting.

There are risks of injuries and accidents caused by flying objects.

Prolonged use of this product exposes the operator to vibrations and can produce so-called "white finger" disease. To reduce the risk, wear gloves and keep your hands warm.

If any of the symptoms of "white finger syndrome" occur, seek immediate medical attention.

Symptoms of "white finger" include numbness, loss of sensitivity, tingling, pain, loss of strength, colour changes or skin condition. These symptoms usually appear on the fingers, hands or wrists. Risk increases at low temperatures.

A long exposition to noise can affect the health of the operator. A hearing protection must be always used when operating the tool. The operation of the tool must be limited and some rest must be taken between two sessions (e.g. 10min of operation and 20min of rest).

### 3. COMPONENT LIST



1	Coupling lever	2	Brake lever
3	Lower handle	4	Knob
5	Rear cover	6	Front handle
7	Side discharge cover	8	Side discharge air path
9	Deck	10	Height adjustment handle
11	Grass catcher bag	12	Recoil starter handle
13	Upper handle		

#### Accessories box

Socket spanner: 1 set



## 4. SPECIFICATIONS

Engine model	FTDT4640ES
Engine displacement	139 cm <sup>3</sup>
Engine max. motor power	2.7kW
Equipment mobility	Self-propelled
Volumes of fuel tank	1 L
Volumes of lubricating oil tank	0.6 L
Cutting width	460mm
Rated speed	Max. 2800/min
Net weight (including engine)	32,5kgs
Guarantee sound power level	96 dB(A)
Measured sound power level	93,7 dB(A) K=1,6dB(A)
Measured sound pressure level	82,1 dB(A) K= 3 dB(A)
Vibrations (L,R)	Left: Max 3,011m/s <sup>2</sup> K =1,5 m/s <sup>2</sup> Right: Max3,024m/s <sup>2</sup> K =1,5 m/s <sup>2</sup>
Adjustable height	25-75 mm

## 5. Intended use

 **This lawn mower has been designed for cutting grass. Any other use is not permitted.**

The lawn mower is suitable for private use in the garden only, lawn mowers for private use are those which are used for cutting grass and lawns in the garden, however not for cutting grass in public parks, playing fields or on farms or in forest.

 **Non-permitted users:**

Persons who are not familiar with the operating manual, children, young people under the age of 16 as well as persons under the influence of alcohol, drugs or medication must not operate the unit.

 **Working hours for gasoline lawn mower**

While it is permitted to use a lawn mower at any time, operators should always show due consideration to others living nearby.

## 6. Assembly

When assembling this machine, please follow the instructions for assembly printed.

- 1) Fit the lower handle on the machine with four bolts as per below three picture. First, release bolts, and then fit the lower handle on the brackets, last ensure bolts that it does tighten enough. Note the bolts should be fixed as below photo and on both sides.



- 2) Connect the throttle wire and self-propelled wire on Bail arm lever. Take the wire head into the hole of starting bail arm lever. Follow below pictures to assemble and ensure the wire won't be loose (throttle wire and self-propelled wire pre-assembled).



- 3) Fit the Upper handle to lower handle. Release two wing nuts on lower handle, as below picture, and then fit the upper handle on lower handle. Ensure the wing nuts are tightened enough.



- 4) There are 8 working position for each wheel, adjust the handle according to below picture.

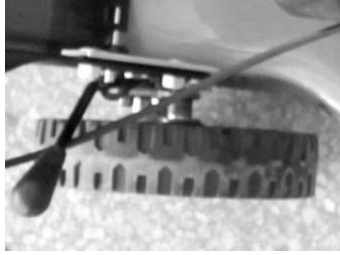

### 5) Electric start model

- Take out the plastic panel from the box.
- Loosen the nut on the upper handle and buckle the plastic panel.
- Align the mounting holes on the plastic panel with the mounting holes on the upper-handle
- Fix the plastic panel with the bolts and nuts and provided.
- Connect the engine cable and battery.
- When charging the battery use the charge socket for 6 hours before use.

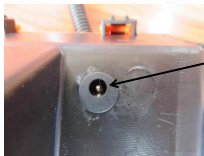

Charging socket

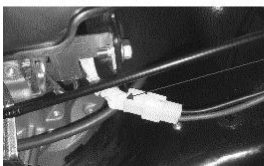

Connecting terminal

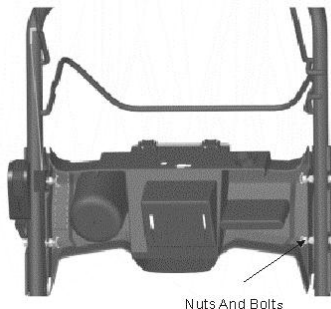

Nuts And Bolts

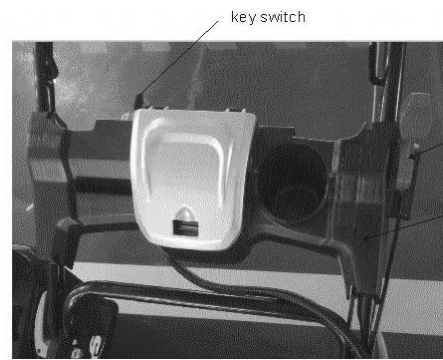

key switch

Throttle

Plastic panel

## Grass Bag Assembly



## Mulching plug

The mulching plug helps to curve the inside of the mower deck for more efficient mulching. Install and remove the mulching plug by raising the rear discharge guard as shown. The mulching plug only fits one way. Remove the mulching plug when using a grass bag.

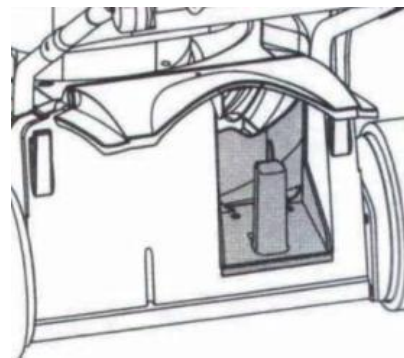
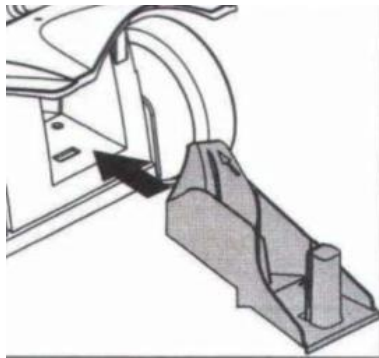
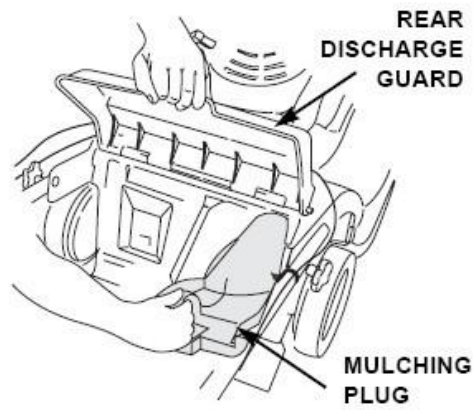

## Side Discharge Cover Assembly

Release the lock of side discharge before lifting the side discharge guard, and then install the side discharge cover on product.

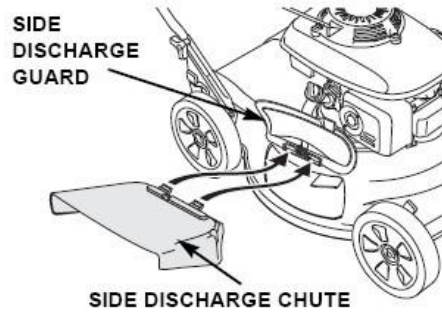

Release the lock of side discharge

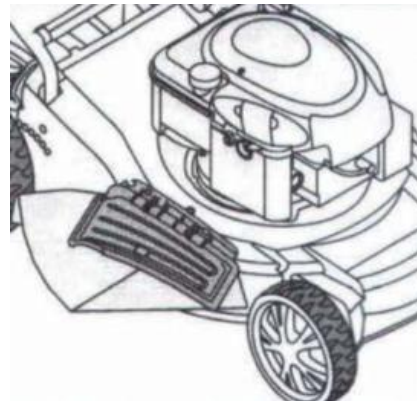
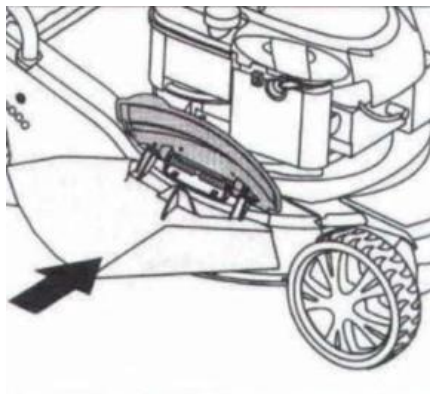
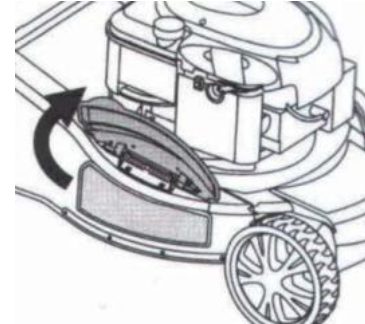
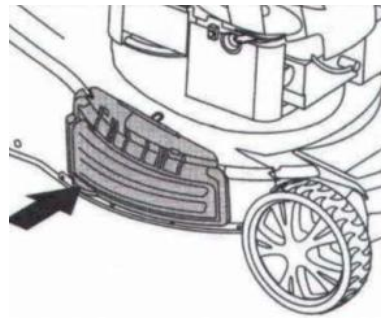



## 7. Use, maintenance and precautions

### Filling with fuel



#### **Danger of injury!**

Fuel is explosive!

**DANGER!**

- Turn off and cool the motor down before filling the tank with fuel.
- You must observe all safety instructions relating to handling fuel.



#### **Risk of device damage!**

The device is supplied without motor or gearbox oil.

**ATTENTION!**

Before operating, you must fill it with motor and gearbox oil.

-Unscrew the tank cap and remove it.



- Pour in the fuel carefully (max.1.5L.). Avoid spilling!
- Screw the tank cap on firmly by hand.

### **Draining fuel**

- Hold a collection container beneath the fuel drain bolt.
- Unscrew the tank cap and remove it.
- Take the machine to bottom up, and drain it. Or take special pumping equipment to empty the jug of gasoline fuel.
- Re do above after several minutes.
- Allow the fuel to run out completely.

### **Filling with motor oil**

Unscrew the motor oil filling bolt and remove it.



- Carefully pour in motor oil (approx. 600 ml). Avoid spilling!
- Check the oil level. The oil level must be between the ADD and FULL marks on the dipstick. If near the lower level, fill to upper level.

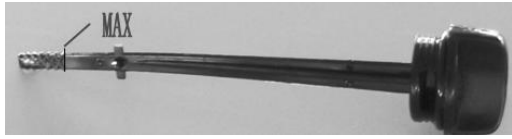

- Tighten the motor oil filling bolt again by hand.

### Draining motor oil

Unscrew fuel tank cap, with a special pumping the oil out or completely to the right side of the machine home, so long into the oil container.

### Start on the unit

Do not start the unit until it has been completely assembled.

Before switching on the unit, always check the oil.

### Check before use!



DANGER!

#### Danger of injury!

Do not operate the device unless you did not find any faults. If a part has become defective, make sure to replace it before you use the device again.

Check the safe condition of the device:

Check the device for leaks.

Check the device for visual defects.

Check that all parts of the device have been securely fitted.

Check that all safety devices are in proper condition.



DANGER!

#### Danger of injury!

Before starting work, always check the ground and remove all objects which could be thrown by the device.

Once the machine has been set up properly, start the engine as follow:

- 1) Before start the machine ,please put the handle bar to “ Start” position



2) Close the starting bail arm lever, as following picture.



3) Pull on the recoil starter handle until you can feel resistance and then pull harshly.

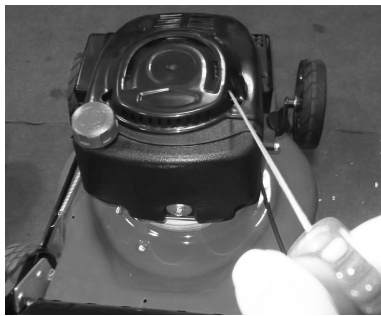

4) When the lawn mower is working ,put the Handle bar to “Run” position

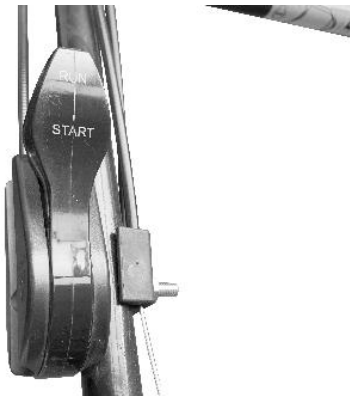

If the engine is in hot standby mode, the engine can start directly.

**⚠** Do not start the motor in tall grass.

**⚠** While mowing, lay the connection cable safely on footpaths and on areas which have already been mown.

4) Press the drive rod. The lawnmower runs without any intervention at a rate of about 3.6 km / h.

Release the drive rod off, and the mower stops.

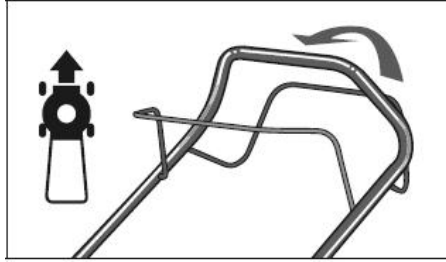

**⚠ When the engine has been switched off, the cutter continues running for several seconds therefore do not touch the underside of the mower until the cutter has come to a standstill!**

**⚠ Bring regular maintenance to the tool. Before performing any maintenance or cleaning work, turn the engine. Check after each use the condition of the tool as explained below. Improper maintenance will reduce the lifetime of the tool, create accidents and injuries and bring bad working results.**

1. Do not spray the unit with water. Ingress of water may damage the engine and electrical connection.
2. Clean the unit with a cloth, hand brush, etc.

<b>Maintenance schedule</b>			
	12 hours of use	24hours of use	36hours of use
Air filter	clean	clean	replace
Spark plug	check	clean	replace
Engine oil	check	replace	check

**Expert inspection is required:**

- a) If the lawn mower strikes an object.
- b) If the motor stops suddenly
- c) If the blade is bent (do not align!)
- d) If the gears are damaged.

Replacing and re-sharpening the mowing blade at the end of the mowing season always re-sharpen the mowing blade or, if required, replace the mowing blade with a new one. Always have the mowing blade re-sharpened or replaced by a customer service centre (measurement of imbalance).

Unbalanced blades will cause the lawn mower to vibrate violently-risk of accident!

**Change the blade**

To remove the blade, unscrew the screw, check the blade support and change all spare parts if they are worn out or damage.

When reassembling the blade, make sure that the cutting edges face in the direction of the engine rotation. The blade screw must be torque to 4.5 K • gm(45Nm) with a dynamometric tool.

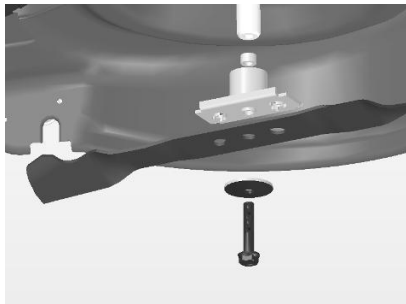

### **Change and clean the spark plug**

- 1) Once the engine has cooled, remove the spark plug using the socket spanner supplied.
- 2) Clean the plug with a wire brush.
- 3) Using a feeler gauge; set the gap to 0.75 mm.
- 4) Install the spark plug carefully by hand, to avoid cross-threading.
- 5) After the spark plug is seated, tighten with spanner to compress the washer.



### **Clean the air filter**

Unclip the air filter cover and remove the sponge filter element. To avoid objects falling into the air tank, replace the air filter cover. Wash the filter element in warm soap water, rinse and allow drying naturally.

#### **⚠ Warning!**

Never run the engine without the air filter element installed.

### **Storing the unit**

After mowing, clean the unit thoroughly. Store the unit in a dry room allow the motor to cool down beforehand. To reduce storage space, the upper handle can be folded down, unscrew the wing nuts by approx 6 revolutions.

### **Troubleshooting**

**⚠ Before performing any maintenance or cleaning work, always turn off the engine and wait until the cutter has come to a standstill.**

**1) Engine does not run:**

- Start on short grass or on an area which has already been mown.
- Clean discharge channel/housing (the mowing blade must rotate freely)
- Correct the cutting height.

**2) Engine power drops:**

- Correct the cutting height.
- Clean discharge channel/housing
- Have mowing blade re-sharpened / replaced (customer service centre)

**3) Grass catcher is not filled sufficiently**

- Correct the cutting height.
- Allow the lawn to dry.
- Have mowing blade re-sharpened / replaced (customer service centre).
- Clean the grille on the grass catcher.
- Clean the discharge channel /housing.

**4) Wheel drive does not function**

- Adjust the flexible cable.
- Check the drive wheels for damage.

Faults which cannot be rectified with the aid of this table may be rectified by a specialist company only (customer service center).

## 8.Declaration of conformity



Declaration of conformity CE

FEIDER

32 rue Aristide Berges -Z1 31270 Cugnaux - France

Tel: +33 (0) 5.34.508.508 Fax: +33 (0) 5.34.508.509

Declares that the machinery designated below:

GASOLINE LAWN MOWER

FTDT4640ES

**Serial number: 20201250136-20201250195**

Conforms to the provisions of the Machinery Directive 2006/42/EC and the national regulations transposing it

Also complies with the provisions of the following European directives:

To the EMC Directive 2014/30/EU

To the ROHS Directive:(EU)2015/863 amending 2011/65/EU

Emission directive (EU) 2016/1628 & 2018/989/EU

Directive 2000/14/EC, Annex VI, and the Directive 2005/88/EC

Also complies with European standards, national standards and the following technical provisions:

EN ISO 5395-1:2013+A1:2018

EN ISO 5395-2:2013+A1:2016+A2:2017

EN 14982:2009

Guarantee sound power level	96 dB(A)
Measured sound power level	93,7 dB(A) K= 1,6 dB(A)

Notified Body 0865

**ISET S.r.l.** Via Donatori del Sangue, 9 46024 - Moglia (MN) Italy

Cugnaux, 19/10/2020

Philippe MARIE / PDG

Responsible of technical file: Olivier PATRIARCA

## 9. WARRANTY



### WARRANTY

The manufacturer guarantees the product against defects in material and workmanship for a period of 2 years from the date of the original purchase. The warranty only applies if the product is for household use. The warranty does not cover breakdowns due to normal wear and tear.

The manufacturer agrees to replace parts identified as defective by the designated distributor. The manufacturer does not accept responsibility for the replacement of the machine, in whole or in part, and/or ensuing damage.

**The warranty does not cover breakdowns due to:**

- insufficient maintenance.
- abnormal assembly, adjustment or operations of the product.
- parts subject to normal wear and tear.

**The warranty does not extend to:**

- shipping and packaging costs.
- using the tool for a purpose other than that for which it was designed.
- the use and maintenance of the machine done in a manner not described in the user manual.

Due to our policy of continuous product improvement, we reserve the right to alter or change specifications without notice. Consequently, the product may be different from the information contained therein, but a modification will be undertaken without notice if it is recognized as an improvement of the preceding characteristic.

**READ THE MANUAL CAREFULLY BEFORE USING THE MACHINE.**

When ordering spare parts, please indicate the part number or code, you can find this in the spare parts list in this manual. Keep the purchase receipt; without it, the warranty is invalid. To help you with your product, we invite you to contact us by phone or via our website:

- **+33 (0)9.70.75.30.30**
- **<https://services.swap-europe.com/contact>**

You must create a "ticket" via the web platform.

- Register or create your account.
- Indicate the reference of the tool.
- Choose the subject of your request.
- Describe your problem.
- Attach these files: invoice or sales receipt, photo of the identification plate (serial number), photo of the part you need (for example: pins on the transformer plug which are broken).





# 10. PRODUCT FAILURE

## WHAT TO DO IF MY MACHINE BREAKS DOWN?

### If you bought your product in a store:

- a) Empty the fuel tank.
- b) Make sure that your machine is complete with all accessories supplied, and clean! If this is not the case, the repairer will refuse the machine.

Go to the store with the complete machine and with the receipt or invoice.

### If you bought your product on a website:

- a) Empty the fuel tank.
- b) Make sure that your machine is complete with all accessories supplied, and clean! If this is not the case, the repairer will refuse the machine.
- c) Create a SWAP-Europe service ticket on the site: <https://services.swap-europe.com> When making the request on SWAP-Europe, you must attach the invoice and the photo of the nameplate (serial number).
- d) Contact the repair station to make sure it is available before dropping off the machine.

Go to the repair station with the complete machine packed, accompanied by the purchase invoice and the station support sheet downloadable after the service request is completed on the SWAP-Europe site

For machines with engine failure from manufacturers BRIGGS & STRATTON, HONDA and RATO, please refer to the following instructions.

Repairs will be done by approved engine manufacturers of these manufacturers, see their site:

- <http://www.briggsandstratton.com/eu/fr>
- <http://www.honda-engines-eu.com/fr/service-network-page;jsessionid=5EE8456CF39CD572AA2AEEDFD290CDAE>
- <https://www.rato-europe.com/it/service-network>

**Please keep your original packaging to allow for after-sales service returns or pack your machine with a similar cardboard box of the same dimensions.**

**For any question concerning our after-sales service you can make a request on our website <https://services.swap-europe.com>**

**Our hotline remains available at +33 (9) 70 75 30 30.**



# 11. WARRANTY EXCLUSIONS

## THE WARRANTY DOES NOT COVER:

- Start-up and setting up of the product.
- Damage resulting from normal wear and tear of the product.
- Damage resulting from improper use of the product.
- Damage resulting from assembly or start-up not in accordance with the user manual.
- Breakdowns related to carburetion beyond 90 days and fouling of carburetors.
- Periodic and standard maintenance events.
- Actions of modification and dismantling that directly void the warranty.
- Products whose original authentication marking (brand, serial number) has been degraded, altered or withdrawn.
- Replacement of consumables.
- The use of non-original parts.
- Breakage of parts following impacts or projections.
- Accessories breakdowns.
- Defects and their consequences linked to any external cause.
- Loss of components and loss due to insufficient screwing.
- Cutting components and any damage related to the loosening of parts.
- Overload or overheating.
- Poor power supply quality: faulty voltage, voltage error, etc.
- Damages resulting from the deprivation of enjoyment of the product during the time necessary for repairs and more generally the costs related to the immobilization of the product.
- The costs of a second opinion established by a third party following an estimate by a SWAP-Europe repair station
- The use of a product which would show a defect or a breakage which was not the subject of an immediate report and/or repair with the services of SWAP-Europe.
- Deterioration linked to transport and storage\*.
- Launchers beyond 90 days.
- Oil, petrol, grease.
- Damages related to the use of non-compliant fuels or lubricants.

\* In accordance with transport legislation, damage related to transport must be declared to carriers within 48 hours maximum after observation by registered letter with acknowledgement of receipt.

This document is a supplement to your notice, a non-exhaustive list.

**Attention:** all orders must be checked in the presence of the delivery person. In case of refusal by the delivery person, it you must simply refuse the delivery and notify your refusal.

**Reminder:** the reserves do not exclude the notification by registered letter with acknowledgement within 72 hours.

### Information:

Thermal devices must be wintered each season (service available on the SWAP-Europe site). Batteries must be charged before being stored.